

TQSF series gravity grading stone remover

Product purpose:

It integrates screening, grading, stone removal and air separation, and has dual functions of grading and stone removal. The machine is an energy-saving special equipment newly developed by our company. It is the most ideal equipment for the cleaning process of domestic grain, chemical industry, feed, alcohol and pharmaceutical factories.

Working principle and characteristics

of the machine:

TQSF series gravity grading stone remover is suitable for efficient separation of high-density impurities such as stone, metal and glass in grain logistics. Its production capacity depends on the specific grain characteristics and its impurity content.

High separation rate - excellent grain cleaning ability

TQSF series gravity grading stone remover has excellent separation efficiency and can effectively remove light stones of grain size from a large number of product streams, ensuring ideal grain cleaning; Excellent separation of high-density particles, such as stone, glass and metal, effectively reduce the wear of impurities and foreign matters on the equipment in the next production process.

There are many products, high production capacity and wide

application fields:

The stone remover is characterized by a wide range of applications: in addition to the standard applications of wheat, rye and corn, TQSF series gravity classification stone remover can also be used for the special processing of oats, buckwheat, barley, Speers wheat and millet, and has been successfully applied to wine making, distillation and the production of ethanol products;

technical parameter



| Type No | yield (T/H) | Sieve amplitude (mm) | Vibration frequency (r/Min) | Re sieving inclination (°) | wind pressure (pa) | Suction air volume (m ³ /MIN) | power (KW) | weight (KG) | Overall dimension (mm) |
|----------|-------------|----------------------|-----------------------------|----------------------------|--------------------|--|------------|-------------|------------------------|
| TQSF-63 | 2-3 | 4-6 | 940 | 5-9 | <980 | 135 | 0.25*2 | 300 | 1200*800*1800 |
| TQSF-80 | 3-4 | 4-6 | 940 | 5-9 | <980 | 145 | 0.25*2 | 340 | 1300*916*1800 |
| TQSF-100 | 6-9 | 4-6 | 940 | 5-9 | <980 | 160 | 0.25*2 | 400 | 1500*1160*1920 |

| | | | | | | | | | |
|----------|-------|-----|-----|-----|------|-----|--------|-----|----------------|
| TQSF-125 | 8-11 | 4-6 | 940 | 5-9 | <980 | 170 | 0.37*2 | 500 | 1470*1496*1920 |
| TQSF-150 | 12-15 | 4-6 | 940 | 5-9 | <980 | 200 | 0.55*2 | 600 | 1200*1476*1920 |
| TQSF-175 | 16-20 | 4-5 | 940 | 5-9 | <980 | 250 | 0.25*2 | 750 | 1200*1990*1920 |

Use and operation of specific gravity grading stone remover

The specific gravity grading and stone removing machine is a common equipment in grain processing plants. Its working principle is to promote the wheat and the stone and heavy side by side with the help of upward air flow according to the different specific gravity and suspension speed of wheat and impurities

Quality wheat and light wheat are separated, so as to achieve the purpose of grading heavy wheat and light wheat and removing stones, mud and sand in wheat. The specific process is shown in Figure 1.

The wheat is first fed into the feed box through the feed pipe, so that the wheat can be evenly fed into the upper screen surface. With the combined action of the reciprocating linear motion of the screen surface and the air flow passing upward through the screen surface and wheat, the light wheat and light impurities float on the material flow, become the sieve on the upper screen surface, and are discharged from the discharge port; Light impurities such as wheat husk and mud ash are taken away from the air suction pipe; When heavy wheat and sand pass through the second and third sections of the upper screen surface, they pass through the screen hole and enter the lower screen surface. Sand, stone, mud, etc. climb up along the steel wire woven screen (surface) to form a stone accumulation area, which is discharged from the stone outlet in turn. Heavy wheat moves downward and is discharged from the heavy wheat outlet. 1. Empty machine commissioning

1) test whether the screen surface swings (i.e. the inclination and levelness of the screen surface). As shown in Figure 2, place 6 M5 nuts evenly at the lower end of the second screen surface of the stone remover. When placing, ensure that the 6 nuts are in the same position

On the straight line, then start the stone remover and observe the trend of 6 nuts. If it reaches the stone outlet at the same time and the arrival time is between 20-30s, it indicates that the inclination and levelness of the screen surface are the best; If the arrival time of 6 nuts is less than 20 # s, it indicates that the inclination angle of the screen surface is too small; If the arrival time of 6 nuts is > 30s, it indicates that the inclination angle of the screen surface is too large; In another case, the direction of the six nuts is irregular, which indicates that the levelness of the screen surface is not adjusted well.

2) air volume test: when the air door is opened to the maximum, the air volume reaches the design air volume required by the stone remover. 2. Load commissioning

L) thickness of flow: make the material cover the second layer of screen surface and move in a wavy "boiling" state. It is

the best if the lower material surface reaches half of the transparent glass observation window. 2) size of reverse wind: control the reverse blowing to form an obvious boundary between stones and wheat (generally about 5 cm in the stone accumulation area). The stone discharging is normal and the grain content in the stone meets the requirements, that is, it is in normal working state and reverse blowing

The distance between the air door and the screen surface should be about 15-20} mm.

3) test of suspension speed: wheat grains bounce on the screen or feel good. 3. Operation

1) a comprehensive inspection must be carried out before startup, such as whether the pressure valve of the storage tank, the regulating damper of the air suction pipe, the flexible rotation, and the convenient adjustment of the back blowing regulating plate. 2) when starting up, close the damper first, slowly open the damper after the fan is running, and start feeding at the same time. ① adjust the main air valve to make the materials cover the second layer of screen surface and move in a wavy "boiling" state;

② adjust the back blowing damper at the stone outlet end and control the back blowing to form an obvious dividing line between stones and wheat (the stone accumulation area is generally about 5cm). The stone outlet is normal, the grain content in the stone meets the requirements, that is, it is normal working state, and the distance between the back blowing damper and the screen surface is about 15 ~ 20 mm; ③ air supplement: adjust according to the "boiling" state of the material

3) during shutdown, stop feeding first, then shut down and turn off the fan to prevent excessive material accumulation on the screen surface from blocking the screen surface and affecting normal operation.

4) adjustment of screen surface inclination: when processing wheat, the screen surface inclination is about 7° , which has been adjusted when the equipment leaves the factory. When processing different materials, the screen surface inclination should be adjusted appropriately, that is, rotate the screen surface inclination adjuster

The handle on the structure changes the inclination of the screen surface.

5) amplitude adjustment: when adjusting the amplitude, just adjust the balance weights at both ends of the vibration motor and rotate the balance weights above. When the two balance weights overlap more, the amplitude becomes larger, and when the overlap is less, the amplitude becomes smaller, all overlap, and the amplitude is the largest. The balance weights on both sides of the motor shall be adjusted uniformly, and the nuts shall be locked after adjustment.

6) adjustment of throwing angle: the throwing angle refers to the included angle between the vibration direction of the screen body and the main shaft. When it is necessary to adjust the relative position of the vibration motor and the main shaft, the throwing angle is changed. If the throwing angle is large, the material will move on the screen surface and jump upward. If the throwing angle is small, the opposite is true. Generally, the throwing angle is 35° , which has been adjusted when the equipment leaves the factory and does not need to be adjusted again.

7) use of amplitude and throw angle indicator panel: the indicator panel is locked. The screws are fixed on the templates on both sides of the screen body. During the operation of the machine, loosen the locking screws and turn the indicator plate. When the six small circles on the plate form one

When the line is straight, it is the correct position indicated, and then lock it. At this time, the reading indicated by the scale line corresponding to the vertical scribed line on the screen body is the vibration throwing angle. At this time, there are two straight lines perpendicular to the vibration direction on the indicator board

It is a linear band, and the bandwidth is the actual amplitude value.

8) regularly clean the stone removal screen surface to prevent screen hole blockage; Regularly check the wear degree of the screen surface. If the wear is too large, it shall be replaced in time to avoid affecting the stone removal effect. 4.

Factors affecting the process effect of specific gravity separation equipment

L) raw materials: moisture, particle size, uniformity, type and quantity of impurities in raw materials are the main factors affecting the process effect of specific gravity separation equipment; If the feeding material contains large impurities, it will affect the normal feeding of the feeding mechanism and make the thickness of the material layer different; If the material contains small impurities, the screen hole is easy to be blocked, which destroys the automatic classification of the material and reduces the separation efficiency.

2) screen surface inclination: the screen surface inclination is related to the flow speed of materials. When other motion parameters are constant, increasing the inclination angle, the material with small specific gravity is easy to slide, and the upward resistance of material with large specific gravity increases; When the inclination angle is reduced, the downward flow speed of materials on the screen surface is also reduced, which affects the equipment output and is not conducive to ensuring the purity of heavy materials.

3) amplitude and vibration frequency: both amplitude and vibration frequency are the main factors affecting the movement speed of materials on the working face. With large amplitude and high frequency, the movement speed of materials is fast and the automatic classification function is strong, which is conducive to the improvement of separation efficiency and equipment output; However, the amplitude is too large, the frequency is too high, the working face vibrates violently, the materials are easy to jump, which destroys the automatic classification of materials, thus reducing the separation efficiency. On the contrary, the slow movement of materials on the screen surface and the thickening of the material layer are not conducive to the automatic classification of materials, which not only affects the separation efficiency, but also affects the output of the equipment.

4) flow: the material on the screen surface shall have a certain material layer thickness; The material layer is too thin to produce good automatic classification, and is easy to be blown through by air flow, resulting in uneven distribution of air flow on the screen surface and reducing the separation efficiency; The material layer is too thick, the air flow resistance increases, the material classification is insufficient, and the contact opportunity between the more important materials and the screen surface is reduced, which also reduces the separation efficiency.

5) air velocity: generally, the average wind velocity of the air flow through the screen surface is $1.2-1.3 \text{ m/s}$. if the air velocity is too small, the force of the air flow on the material will be reduced, and the material is not easy to form suspension or semi suspension on the screen surface

In the floating state, the automatic grading of materials is poor, reducing the separation efficiency; If the air velocity is too high, the material layer on the stone removal face is easy to be blown through, and the air distribution is uneven, which destroys the automatic classification of materials and also reduces the separation efficiency. 5. Common faults and cause analysis

1) low stone removal efficiency may be due to:

① the material flow is too large, the air volume is too small, the stone removal screen surface or uniform air plate is blocked, and the fan is reversed; ② the material flow is too small, the air volume is too large, the screen surface is uneven, and the material or air flow distribution is uneven; ③ the reverse air velocity is too high, the stone discharge is not unobstructed, the transmission parts are damaged and the motion track is inaccurate; ④ the stone removal screen surface is worn or the inclination angle is too large. 2) there is much grain in the stone, which may be due to:

① the total air volume decreases, and the reverse air velocity in the inspection area is too small;

② the material flow is too large, the material layer is too thick, the wind resistance is too large, and the automatic classification is not good; ③ the reverse air flow velocity in the inspection area is too small, air leakage or screen hole blockage in the inspection area; ④ the inclination angle of stone removal screen surface is too small; ⑤ the amplitude is too small.

3) The reasons for the failure of the stone outlet may be: ① the inclination angle of the stone removal screen surface is too large;

② the material flow is too small, the fan speed is too high, and the total air volume and the reverse air flow speed in the inspection area are too large. 6. Process index

1) sand removal efficiency $\leq 95\%$;

2) complete wheat grains contained in sand $\leq 70-100$ grains /



图 1 比重分级去石机工作原理示意图

kg.

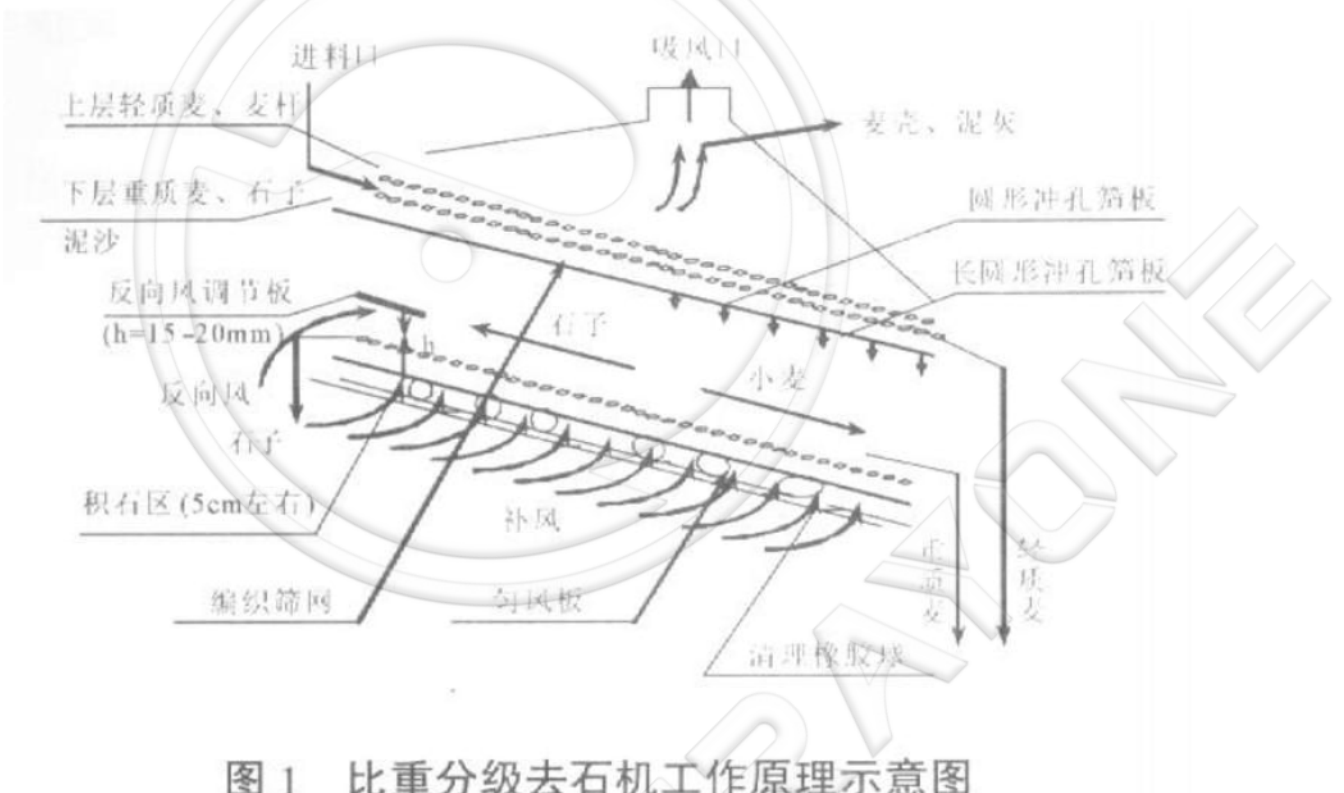
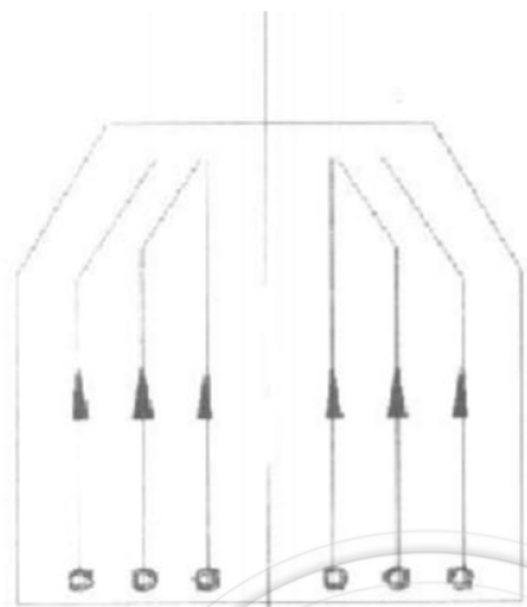

图 2 6 颗 M5 螺母在筛面上的走向

MCRAYONLINE